

Ground Systems

RCB-4000 Digital Receiver System, IRIG Tier-II Compatible – Fully Independent RF Tuning Ground Products/Microdyne



FEATURES

Microdyne's Model RCB-4000 compact receiving system unit combines two high performance telemetry receivers, a dynamic Pre-Detection Diversity Combiner, a DSP-based Multi-mode Demodulator with programmed FIR IF and Video Filters, and an optional programmable Bit Synchronizer within a single 5.25 in rack mounted chassis. The receiving system unit offers the following features and performance characteristics:

- Fully compatible with IRIG Tier-II Phase Noise specifications.
- Dual Independently Tunable Receivers with multiple first and second IF bandwidths, an internal Pre-D AM/AGC Controlled Diversity Combiner, a Wideband DSP-based Digital Multimode Demodulator, and optional Bit Sync.
- Excellent Adjacent Channel Rejection by using multiple SAW First IF bandwidth filters along with highly selectable FIR second IF filters.



communications

Telemetry & RF Products

Excellence You Can Measure

Features (Continued)

- Optimal Ratio Combiner using high speed AGC/AM driven control signals. Combiner may be operated in Optimal Select mode for frequency diversity.
- Superior handling of Fast/Deep fades (50 kHz Combiner Break Frequency).
- Multiple, User selected second IF FIR preprogrammed filters. Bandwidths from 50 kHz to 30 MHz are available for each channel. The unit comes preprogrammed with all IRIG filters. Other bandwidths can be programmed (consult factory).
- Multimode FM, PM, AM, BPSK, QPSK/OQPSK Demodulator.
- Compatible with both conventional Auto-Tracking Antenna Systems and Linear Predictor Antenna Tracking Systems (common in Phased Array Antennas).
- Small, lightweight & rugged design
- Easy to use Front Panel and Remote Control via RS-232, Ethernet and IEEE-488.
- Windows Application Software supplied, providing remote operation of front panel controls via Ethernet interface.

*Feher Patented FPQSK Technologies

OPTIONS:

- Internal single or dual channel programmable Bit Synchronizer with data rates from 30 kbps to 20 Mbps, NRZ and Biphase -L, M & S. Also includes de-interleaver and 3 bit soft decision per I and Q outputs. See 3362 data sheet for detailed dual bit sync specifications.
- Multi-Band Tuners
- 3 Channel record Down Converter (CH1, CH2, Combined)
- Feher Patented *FQPSK Demodulation
- SOQPSK Demodulation
- Trellis FM Demodulator for improved signal-to-noise ratio
- Spectrum Display Unit

RCB-4000 APPLICATIONS

Applications include:

- Data Reception
- AM Tracking Receiver
- Signal Analysis
- Satellite TT&C
- Satellite image reception
- Aircraft testing and evaluation
- Video reception from RPV/UAV vehicles
- Expendable launcher data collection
- Unmanned telemetry sites requiring complete computer control
- Low Earth Orbit (LEO) satellite data collection
- Mobile tracking and data systems

- Microdyne has been manufacturing general and special purpose receivers and combiners for over 30 years and continues to be the undisputed leader in telemetry receiving products which enable highly sophisticated data and signal processing over a wide frequency spectrum. The RCB-4000 exemplifies this leadership with state-of-the-art performance in a compact, easy-to-use form factor.

RCB-4000 BENEFITS

RCB-4000 Digital Receiver System - leading edge technology and performance

This advanced digital technology with flexibility will provide customers with viable technology as requirements develop for years to come. This phenomenal design has resulted in a broad array of benefits.

BENEFITS:

- Internal bit synchronizer eliminates need for external components
- Easy-to-use front panel controls all operations resulting in saving setup time, eliminating errors and resolving status issues
- Programmed digital FIR filters eliminate costly IF upgrades
- Two independent receivers and one Combiner in a single package
- The combiner allows for both polarization and frequency diversity.

REDUCES:

- Rack Space
- Power consumption
- Rack wiring problems
- Cost
- Weight
- Remote control complexities
- Spares
- Maintenance issues

Simplified Block Diagram

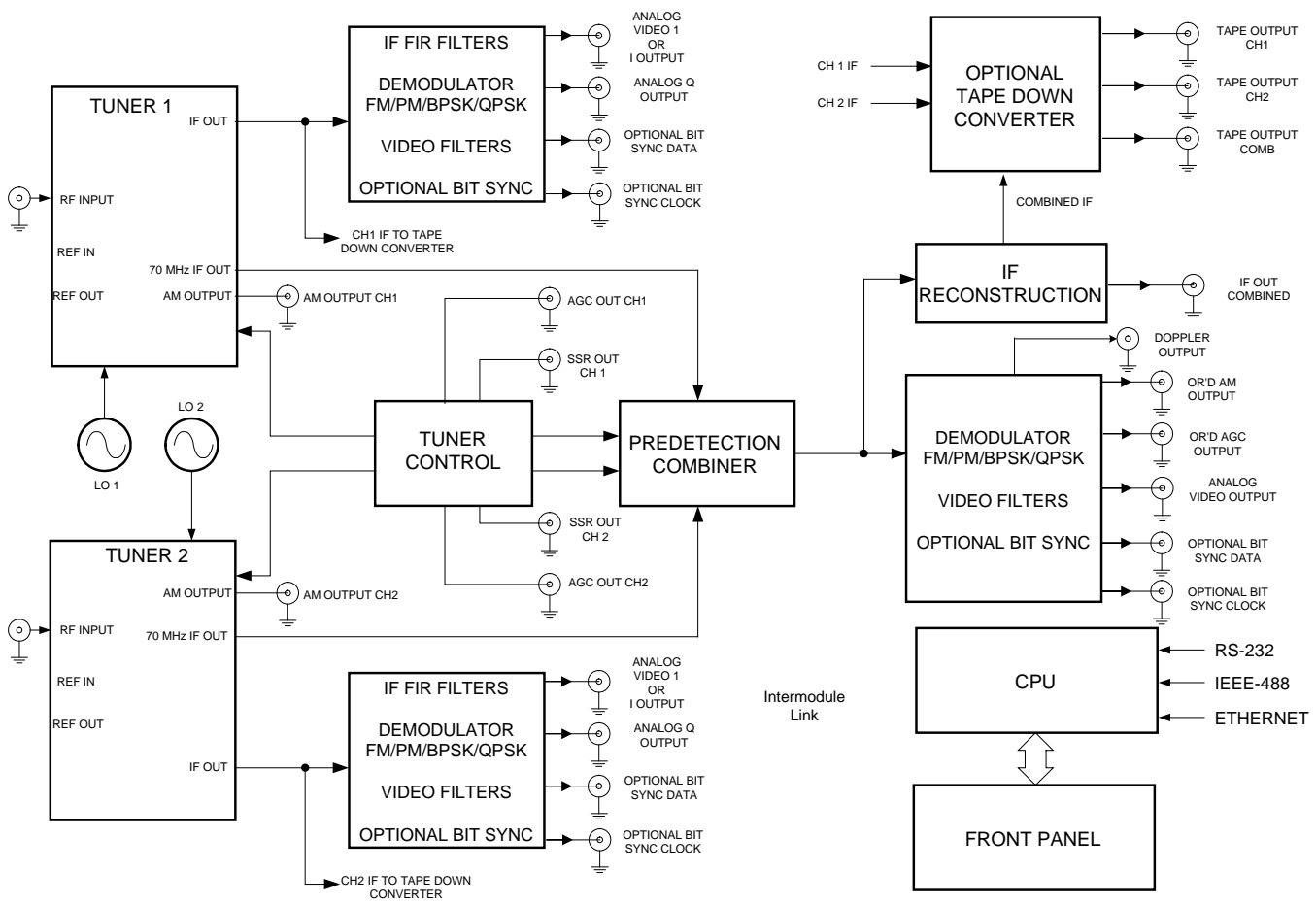

Single-Ended Bit Synchronizer Diagram

Single-Ended Bit Synchronizer Diagram

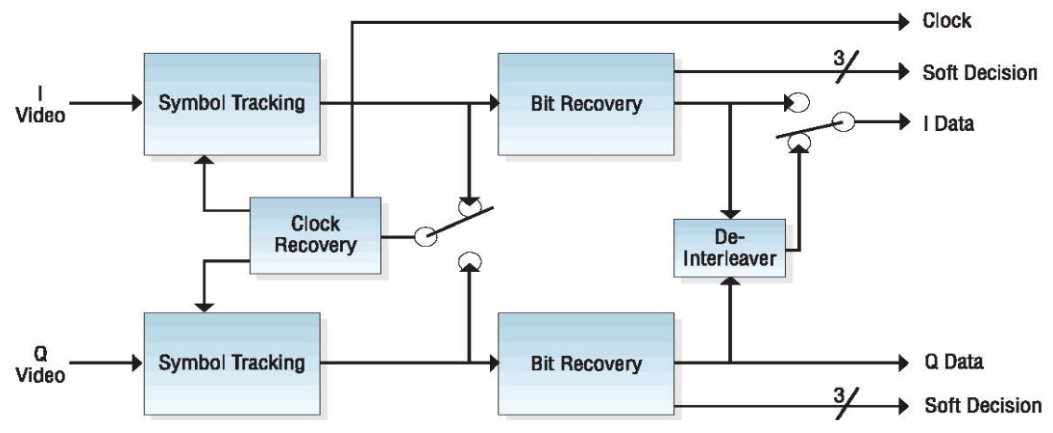

TUNER

The RCB-4000 contains a dual channel tuner in the base unit covering the same frequency band with an option to add up to two additional tuner bands. Tuners are independently tunable, thus allowing for frequency diversity.

Available frequency ranges include: 2185 MHz to 2485 MHz, 1429 MHz to 1545 MHz, 1700 MHz to 1850 MHz and 215 MHz to 320 MHz. The tuner's center frequency can be selected with a resolution of 100 kHz either from the front panel or by remote control. For other frequency ranges, consult the factory.

The RCB-4000 Series has both an internal 10 MHz reference oscillator and the ability to use an external 10 MHz or 5 MHz reference.

AM detection is provided after the 2nd IF FIR filters, providing excellent adjacent channel rejection. The AM frequency response is determined by selection of the AGC time constant and the IF bandwidth. Individual AM outputs are provided for each tuner in the standard configuration.

Envelope AGC is derived from a peak AM detector with five selectable time constant settings.

A programmable manual gain control is provided for each RF Section, which is controlled through the remote digital interface or by the front panel.

The RCB-4000 provides the capability to freeze the gain of the receiver with the remote digital interface or via the front panel. Receiver gain is held to the value at the time the Freeze command is detected.

AGC monitor outputs are provided for each RF section. An AGC zero capability is provided to optimize the performance of the Pre-Detection Combiner. Adjustment of this offset does not affect AGC slope. Auto zero capability is programmable through the remote digital interface or through the front panel. A single control for each receiver channel zeros the AGC monitor outputs.

Additional signal strength record outputs are provided with switchable output polarity.

TUNER SPECIFICATIONS

RF Dual

Conversion Superheterodyne

Frequency Ranges Available

2185-2485 MHz, 1429-1545 MHz, 1700-1850 MHz
215-320 MHz (others available)

Second IF Center Frequency

70 MHz

AM Output Level

2 Vp-p into 75 ohm for 50% modulation

Envelope AM Frequency Response

High end response 50 kHz Low end response determined by AGC TC

Receiver LO Stability

±1.5 ppm

AGC Type

Envelope

AGC Time Constants

0.1, 1, 10, 100, 1000 mS

Receiver Tuning Resolution

100 kHz

Manual Gain, AGC Freeze

Variable by digital control

Noise Figure

8 dB max.

Image Rejection

60 dB

Input Impedance

50 ohms (unbalanced)

VSWR

1.5:1 Typical, 2.0:1 max

Operating Dynamic Range

Threshold to -10 dBm

Maximum Input

+10 dBm

IF Rejection

70 dB min., 80 dB typical

Spurious Rejection

60 dB

First LO Type

Synthesized

DIVERSITY COMBINER

The RCB-4000 provides circuitry for diversity pre-detection combining of the incoming signals. The combining takes place at 70 MHz. Selections are offered through the front panel or through the remote interfaces to perform Optimal Ratio Combining for polarization diversity combining. The combiner may be operated in Optical Select mode for frequency diversity applications, thus eliminating the need for a post-detection combiner.

When operating under normal conditions, the AGC levels from the tuners are a true measure of the quality of the received data, and combiner weighting is a direct function of these levels. Certain applications, (high multipath environments, for example), may require that the combiner weighting include the addition of an AM component. This is handled in the combiner where the AM component is summed with the AGC levels to provide optimal combining under high fade rate conditions.

The Pre-Detection Combiner provides 2.5 dB signal-to-noise improvement with equal S/N ratio inputs. (With unequal inputs S/N ratio) $S/N \text{ combiner} = 10 \log (pr1 + pr2) - .5 \text{ dB}$. Where $Pr1 = C/N$ power ratio CH1 and $Pr2 = C/N$ power ratio of CH2.

DIGITAL FIR IF FILTERS

The internal pre-programmed FIR Second IF filters provide bandwidths from 50 kHz to 30 MHz without the need for module replacement.

Bandwidth selection is made through the remote interfaces or by the front panel. All standard IRIG filters are included. Contact factory for additional filter requirements.

The standard delivered FIR filters offered are as follows: 50 kHz, 100 kHz, 150 kHz, 300 kHz, 375 kHz, 500 kHz, 750 kHz, 1 MHz, 1.3 MHz, 1.5 MHz, 2 MHz, 2.4 MHz, 3 MHz, 3.3 MHz, 4 MHz, 5 MHz, 6 MHz, 7.5 MHz, 10 MHz, 12 MHz, 15 MHz, 20 MHz, 22 MHz, 25 MHz, 30 MHz.

DIGITAL MULTI-MODE DEMODULATOR

The Multi-Mode Demodulator employs the latest application specific technology in processing the 70 MHz IF signal. The demodulator provides FM, PM, BPSK, QPSK/OQPSK, and optional *FQPSK and SOQPSK operation. Data rates of up to 20 Mbps can

be supported. The flexible nature of the demodulator and its associated IF and video filtering allows it to be used for a wide range of applications and it can easily be reconfigured as applications change.

Two analog video outputs are provided for monitoring both I & Q channel video signals in QPSK/OQPSK and **optional *FQPSK** operation. Programmed FIR video filters provide maximally flat group delay filters. Video filters are provided with the -3 dB bandwidths from 150 kHz to 15 MHz.

Video filter values are as follows: 150 kHz, 187.5 kHz, 250 kHz, 375 kHz, 500 kHz, 750 kHz, 1 MHz, 1.2 MHz, 1.5 MHz, 1.65 MHz, 2 MHz, 2.4 MHz, 2.5 MHz, 3 MHz, 3.3 MHz, 3.75 MHz, 4 MHz, 5 MHz, 6 MHz, 7 MHz, 7.5 MHz, 10 MHz and 15 MHz.

Custom video filter bandwidths can be implemented by changing the receiver firmware (contact factory).

The RCB-4000 provides user controllable video output levels with 63 dB levels in 1 dB steps. The user can also control the video coupling (AC/DC) and video polarity.

DEMODULATOR SPECIFICATIONS

Demodulation Modes

FM, PM, AM, BPSK, QPSK/OQPSK, *FQPSK (option), SOQPSK

Acquisition and Tracking

±250 kHz

Doppler Tracking Center Frequency

2.8125 MHz nominal

Reference Stability

±1.5 ppm

Video Output Level (Adjustable)

4 Vp-p nominal, 8 V pp max

Video Bandwidths

Digital FIR

Video Output Impedance

75 ohms unbalanced

Reference Oscillator

10 MHz Internal, 5 or 10 MHz External

RECORD TAPE CARRIER (OPTIONAL)

Record carrier outputs are available as an option for each receiver channel and for the combiner. Record carrier frequencies, selectable through the remote digital interface or through the front panel, are in 25 kHz steps from 25 kHz to 20 MHz. The record carrier output level is 1 V RMS. The output impedance is 75 ohms.

PROGRAMMABLE BIT SYNCHRONIZER (OPTIONAL)

An **optional programmable Bit Synchronizer** is available inside the RCB-4000 supporting data rates up to 20 Mbps per channel. The outputs of the bit sync are NRZ-L data with clock along with three soft decision bits for I & Q channels. The user can select the following:

- Input code - NRZ-L/M/S, Bi-Phase-L/M/S
- Bit Rate - 30 kbps to 20 Mbps (NRZ-L) per channel
- De-interleaver - in or out (10 Mbps maximum)
- Clock and data polarity per channel maximum control
- 15 bit Derandomizer on or off

Settings can be changed via the front panel or through the remote digital interface.

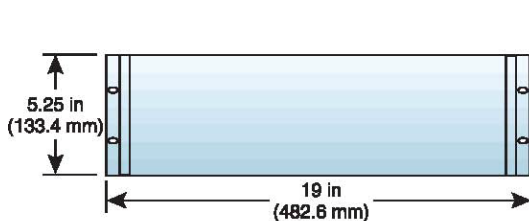

SPECTRUM DISPLAY UNIT (OPTIONAL)

The SDU unit provides basic spectrum analyzer capabilities to the RCB-4000. The SDU unit allows the user to view incoming RF spectrum on channel 1 and 2. This allows the user to verify that the input signal is compatible with the receiver configuration. Additionally, the spectrum can also be provided to a remote computer via the standard RCB-4000 remote interfaces. An additional 70 MHz input is provided on rear panel.

SDU SPECIFICATIONS

Display

Logarithmic 60 dB

Span

50 kHz to 20 MHz (selectable)

Reference Amplitude

-10 to -40 dBm (selectable)

Resolution Bandwidth

1 kHz to 300 kHz (selectable)

Video Bandwidth

1 kHz to 300 kHz (selectable)

Inputs

Ch1, CH2 and External (70 MHz)

Markers

Peak & Delta Measurements (selectable)

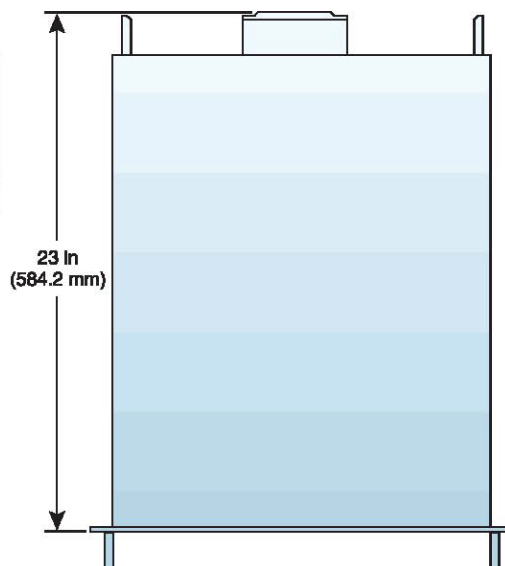

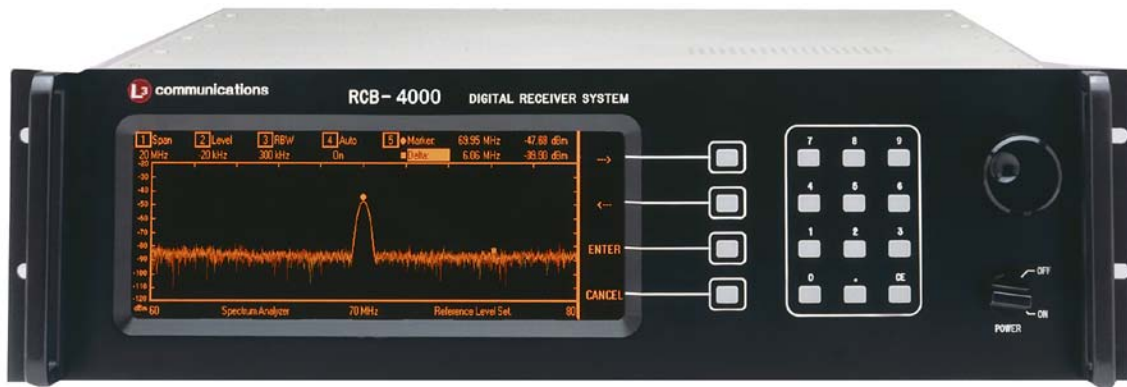

RCB-4000 General Specifications

RCB-4000 General Specifications

Graphics Display Type	Electroluminescent	Operating Temperature Range	0 to 50 degrees C
Graphics Display Size	3" x 8.25"	Non-Operating Temperature Range	-55 to + 65 degrees C
Graphics Display Color	Amber on Black	Humidity	Up to 90% non-condensing
Data Entry	16 Button Keypad	EMI/RFI	Designed to meet 89/336/EEC
Stored Setups	Stores up to 9 setups in non-volatile memory	Dimensions	5.25" H x 19" W x 22" D
AGC Modes	AGC, Manual Gain, AGC Freeze	Weight	Less than 45 lbs.
Interface Baud Rate	Up to 19.2 Kbps	Power Requirements	115/230 VAC (auto select) 50 - 400 Hz 200 watts maximum
Remote Interface Formats	Ethernet, IEEE-488.1, RS-232		

RCB-4000 Rear Panel Connector

RCB-4000 Rear Panel Connector

Connector	Function	Connector Type	Connector	Function	Connector Type
J1	115/230 VAC, 50-400 Hz auto select	IEC-320 Appliance AC connector with strain relief	J15	AGC Channel 2, 0 to -5 V into a 1K load	BNC
J2	RF Channel 1 Input, 50 ohm unbalanced	N	J16	IF Channel 2 Out, 70 MHz, -10 dBm, 50 ohms	BNC
J3	RF Channel 2 Input, 50 ohm unbalanced	N	J17	Record Out CH. 2 (option), 75 ohms	BNC
J4	Video Out 1, nominal 4 Vp-p, 75 ohms	BNC	J18	OR'D AM 2Vp-p for 50% AM, 75 ohms	BNC
J5	Video Out 2, nominal 4 Vp-p, 75 ohms	BNC	J19	OR'D AGC , 0 to -5 V into a 1K load	BNC
J6	Signal Strength Record Channel 1, 0 to +5 V or -5 V into a 1K load	BNC	J20	IF Combined Out, 70 MHz, -10 dBm, 50 ohms	BNC
J7	10 MHz Reference Out, 50 ohms	BNC	J21	Record Out Combined (option), 75 ohms	BNC
J8	AM Channel 1 Output, 2 Vp-p for 50% AM, 75 ohms	BNC	J22	Doppler, 2.8125 MHz	BNC
J9	AGC Channel 1, 0 to -5 V into a 1K load	BNC	J23	Bit Sync Outputs - Soft decision, Clock and Data, (TTL levels)	Type "D", 15 pin female
J10	IF Channel 1 Out, 70 MHz, -10 dBm, 50 ohms	BNC	J24	Accessory	Type "D", 25 pin female
J11	Record Out CH. 1 (option), 75 ohms	BNC	J25	RS-232C Interface	RS-232C Standard 9 pin, Type "D" female
J12	Signal Strength Record Channel 2, 0 to +5 V or -5 V into a 1K load	BNC	J27	Ethernet, 100Base-TX	RJ-45 Socket
J13	10/5 MHz Reference In, 50 ohms	BNC	J28	IEEE-488.1 Interface	IEEE-488.1 Standard
J14	AM Channel 2 Output, 2 Vp-p for 50% AM, 75 ohms	BNC	J29	Channel 1 Video Out	BNC
			J30	Channel 2 Video Out	BNC

Note: Rear panel configuration may vary depending on the options chosen.



www.L-3Com.com/te



L-3 Communications Telemetry-East
 1515 Grundy's Lane
 Bristol, PA 19007
 Tel: 267-545-7000
 Fax: 267-545-0100



communications
 Telemetry-West

L-3 Communications Telemetry-West
 9020 Balboa Avenue
 San Diego, CA 92123-3507
 Tel: 858-694-7500, 800-351-8483
 Fax: 858-279-0693